

ELEMENTS OF DESIGN



AIR SCREENS



CONTOURA™



DECO-TECH



SOLERA™



DRAN-TECH



ZGUARD®



STEALTH HEAT



ZSPACE™



COLD PANS



EURO+SERVE





TABLE OF CONTENTS

AN INTRODUCTION TO ZGUARD5-6

ZGUARD ZG95008

ZGUARD ZG99159

ZGUARD ZG95609

ZGUARD ZG993010

ZGUARD ZG994511

ZGUARD ZG700012

ZGUARD ZG960013

DECO-TECH 900 SERIES16

ENGINEERED FOOD SHIELDS21

ZGUARD MOUNTING OPTIONS24

FINISHES25

OVERHEAD HEAT LIGHTS/WARMERS ...26

ZSPACE30-35

CONTOURA COUNTER SYSTEM38-41

EURO+SERVE COUNTER SYSTEM44

AIR SCREENS45

ICE PANS45

HEATED MERCHANDISERS48-49

DRAINS50

SINKS50

THE ZGUARD ADVANTAGE

Known for cutting-edge design, unparalleled functionality and complete adjustability, ZGuard is now the industry standard for quality, design and control. No food shield does it better.

Create a new service concept in minutes. Totally adjustable glass panels can be moved to any height or angle using the precision die-cast bracket and post system. The adjustable brackets enable glass panels to rotate a full 360° to serve as horizontal shelves, angled displays, or serve as full-service or self-serve food shields.

MODULAR DESIGN FOR TODAY AND TOMORROW

Change your counters; rework your floor plan without having to replace your system. ZGuard's component-based modular design works to meet your needs today and quickly respond to tomorrow's trends.

COMPLETE FLEXIBILITY TO HANDLE EVERY NEED

Attach lights, warmers, shelves, or signage with ease. Take your servery to the next level with ZSpace merchandising accessories. Check out pages 30-35 to see how to use ZSpace to custom design your own merchandising solutions.

UL RECOGNIZED

ZGuard is UL recognized to integrate the food shield tubing as conduit for electrical. This gives you the flexibility to expand food shield designs using heat and/or lights without unsightly wire chases.



ZGUARD: THE TOTAL SOLUTION

Say goodbye to the limitations of the traditional welded "sneeze guard." ZGuard renders the unsightly, impossible-to-change, traditional welded "sneeze guard" obsolete. Comprised of precision component pieces, ZGuard lets you design and change your mind and your service concept like never before.

In addition, when you use our line of ZSpace and ZSign merchandising products in conjunction with ZGuard, you get a servery that is functional, flexible, beautiful and profitable. ZGuard, ZSpace and ZSign lets your servery soar! The only limit is your imagination.

WHEN YOU USE ZGUARD, YOU'LL ENJOY ALL THESE FEATURES AND BENEFITS :

- | | |
|---|---|
| <u>Infinite adjustable glass height</u> | <u>Cost effective –can be configured to fit any budget</u> |
| <u>360° adjustable glass angle</u> | <u>Easy to clean and maintain</u> |
| <u>Flexible layout options</u> | <u>Solid, high-quality precision die-cast components</u> |
| <u>Quickly adapts to any health code</u> | <u>Replacement parts in stock</u> |
| <u>On-the-fly design</u> | <u>Complete shop drawings and plans provided with every unit</u> |
| <u>Spontaneous reconfiguration</u> | <u>Electronic plans available for each unit</u> |
| <u>Shortest lead times in the industry</u> | <u>Unparalleled customer support</u> |
| <u>Easily fits radius or unique counter shapes</u> | <u>Smallest and most efficient warmers, lights and heat/light combo</u> |
| <u>Quick and easy installation</u> | <u>In addition to glass, top-shelf material may be any hard decorative surfaces such as wood, metal or stone.</u> |
| <u>No special tools needed for height or angle adjustment</u> | |
| <u>Easy design problem resolution</u> | |
| <u>Mounts to any counter or cart</u> | |
| <u>Low profile, clean design</u> | |
| <u>NSF Listed</u> | |
| <u>UL Listed</u> | |







ZGUARD MODEL ZG9500

ZG9500

This is the original! Unparalleled in flexibility and adjustability, this is our most popular food shield model. Use it for full-service, self-service or any combination. Quickly add pass-over shelves, display shelves or both. This series offers limitless configurations and mounts to any counter or mobile cart on the market.



ZG9500-2



ZG9500-3



ZG9500-5



ZG9500-6

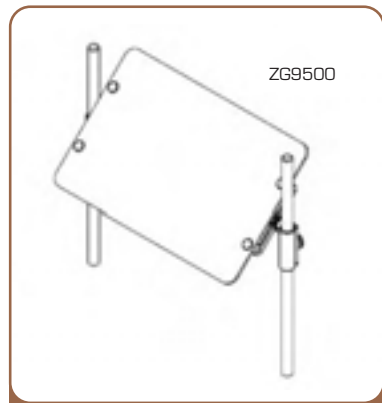

ZG9500

ZG9915

When you want to add lights, warmers and a super-strong top shelf, this attractive and functional series has everything you need. Create a self-serve, full-serve or combination service line. Use the top passover shelf for grab-and-go items, or as an opportunity to merchandise your cafeteria.

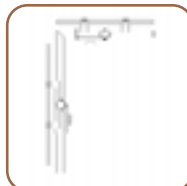

ZG9560

Want a totally different look? The 9560 takes a new slant on style. It offers the same functionality as the 9500, but adds a more modern twist.

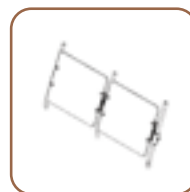

ZGUARD MODEL ZG9930

ZG9930

For high-volume environments, this offers the ultimate in flexibility. Designed for single-sided or double-sided serving lines, the 9930 lets you incorporate top shelves or multiple-tier display shelves into your design for pre-prepared "grab and go" items.



ZG9930-3



ZG9930-2



ZG9930-5



ZG9930



9945 EZ SPAN™

Are long spans part of your plans? If so, the answer is EZ Span. The 1.5" tubing structure provides the ability to safely span up to eight feet without center supports! Adding a top shelf is no problem either. The full range of applications is available, too, including warmers and lights. Durable, safe and strong—that's EZ Span.



ZG9945-5



ZG9945-4



ZG9945-3

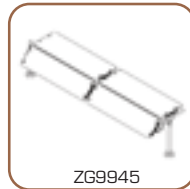

ZG9945

ZGUARD ZG 9945 EZ SPAN

ZGUARD MODEL ZG7000 SERIES

ZG7000 SERIES

Nothing says style like curves. Now we have them. From simple self-serve profiles to multiple curve profiles for full-serve operation, we have a solution for every need.

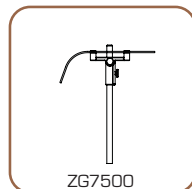

ZG7500

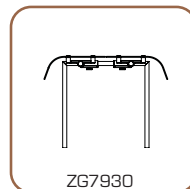

ZG7930

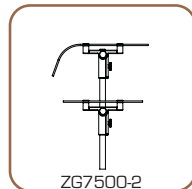

ZG7500-2

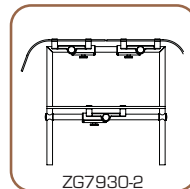

ZG7930-2



ZG7700



ZG9600 MARKET/PORTABLE ZGUARD :

When catering and special events are part of your recipe, depend on the portable protection of ZGuard's 9600 series.

It comes standard with a counter top aluminum support stand and is available in various lengths. This is the perfect solution for carving stations, dessert stations, and much more.



ZG9600







DECO 900 SERIES ADJUSTABLE FOOD SHIELDS

If you are looking for a different take on the adjustable food shield, then look to the Deco 900 Series of food shields. Not only is it an elegant solution, you can customize the bracket channel to get a unique, exclusive look. You can create logos, laser cut patterns or what ever you can imagine.

Posts and mechanisms are made of stainless steel. Both are available in a full range of powder coat colors and finishes.

The Tension Ring allows for vertical adjustment and is easy to grasp and tighten without tools. Full perimeter pressure ring leads to weight-bearing capacity of 100lbs. capacity per shelf.

Angle adjustment is done with a simple spring loaded pull pin which allows glass to be unlocked and rotated 360° freely. The glass rotates in 22 degree increments. Glass is available in 1/4", 3/8" and 1/2".



CREATE CUSTOM DECO BRACKETS





DECO-970



DECO-901



DECO-900



DECO-953



DECO-902



DECO-932



DECO-950



DECO-965



DECO-TECH FOOD SHIELDS



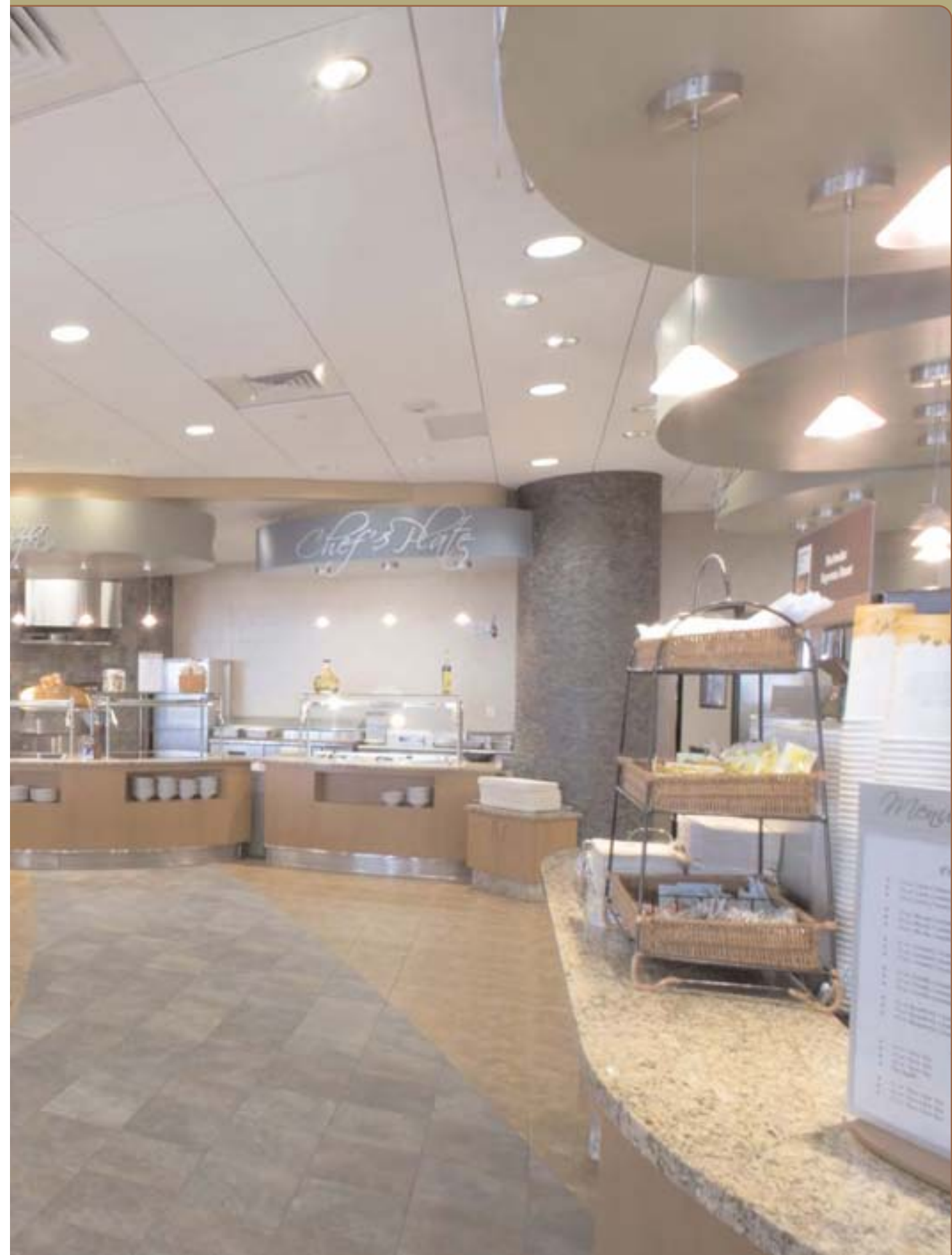

ENGINEERED FOOD SHIELDS

While most people know us as the "ZGuard" company, we build hundreds of high-end, highly technical custom food shields each year. We are involved in some of the most prominent hotels, casinos and public space food shield projects being built today.

In addition to our extensive list of hundreds of "catalog" food shield styles, we can help you design and build a custom food shield that is uniquely your own.

Our extensive line of custom food shields allows you to easily pick the perfect food shield for your application or create your own design that meets your unique specifications. All our food shields are available in a variety of finishes including stainless steel, brass or your choice of powder coat colors.

Our state-of-the-art design and manufacturing platform ensures a perfect fit with your counter and, more importantly, total satisfaction with the finished product. These features, combined with short lead times, make any of the Brass Smith food shields today's leader in food shield design and fabrication.



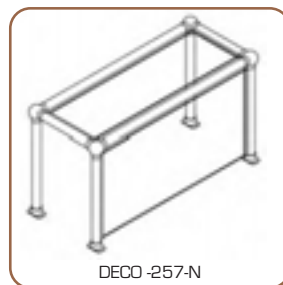
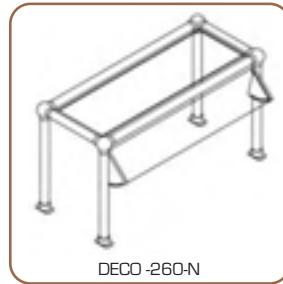
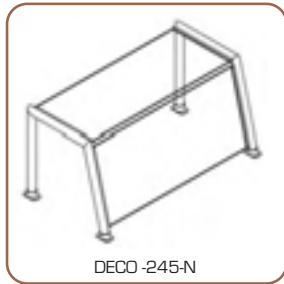

A FEW OF OUR MOST POPULAR ENGINEERED MODELS





WE HAVE THE SOLUTION FOR ANY COUNTER OR CART

With the most comprehensive and innovative mounting options in the industry, the power of ZGuard works anywhere.

Millwork or fabricated counters, wall or ceiling mounts or mobile carts - there's nothing we can't fit. Plus it's one of the strongest mounts in the industry. No wiggle room, no hassle.

Retrofitting to existing counters? No problem! When budgets are tight, designers can keep existing counters and upgrade the food shields to ZGuard.

ZGUARD MOUNTING OPTIONS



MWU3
BELOW COUNTER
NARROW FLANGE

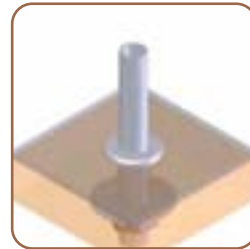

MWU4
BELOW COUNTER
COMPRESSION MOUNT



MWU5
BELOW COUNTER
HEAVY DUTY FLANGE

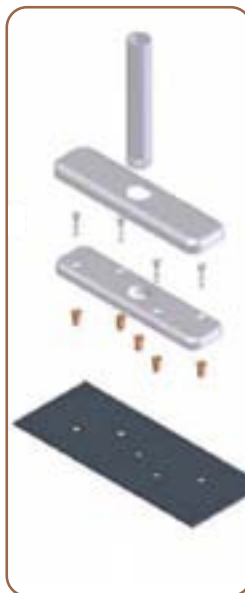

SS1
ABOVE COUNTER
EZ MOUNT

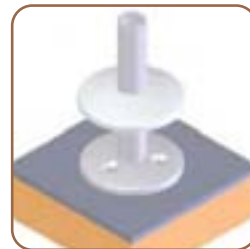

MW1
ABOVE COUNTER
HEAVY DUTY FLANGE



MW2
ABOVE COUNTER
NARROW FLANGE

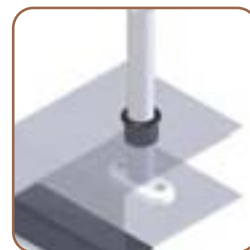

SSU2
BELOW COUNTER
NARROW FLANGE



SSU3
BELOW COUNTER
HEAVY DUTY FLANGE

FINISHES

With dozens of available colors and finishes, your food shields can be designed to accent any decor. From natural metals to the exclusive Luster Rail® powder-coated finishes, ZGuard is at home in the most traditional environments or modern spaces. Our 6 stock finishes (shown below) are NSF Listed. Plus, choose from dozens of other NSF Listed colors.

Can't find a finish that suits your style? Don't worry, we'll create a custom color or finish that is uniquely your own.



JET (GLOSS) BLACK



WRINKLE BLACK



CHROME



BRUSHED ALUMINUM



BRASS FINISH



COPPER FINISH

TURN UP THE HEAT WITH GREAT DESIGN

Our exclusive Stealth Warmer™ offers a sleek, curved profile that is only 2.5" high and 4" wide and it comes in a variety of lengths. Let your customers see the food, not the warmer.

EFFICIENT

Despite its diminutive profile, compared to any other industry brand, the Stealth Warmer can't be beat on consistent heat. It out performs any other warmer by as much as twenty percent.

SAFE

With the lowest touch temperature in the industry, you don't have to worry about accidental burns. In addition, with a remote infinite switch, you can turn it on and off with ease and safety.

INNOVATIVE

Quality heat output and innovative design makes this "The New Industry Standard" in warmers. But would you expect anything less from the company that brought you ZGuard?

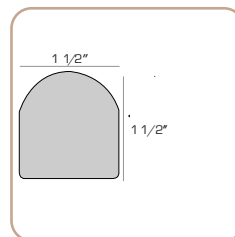
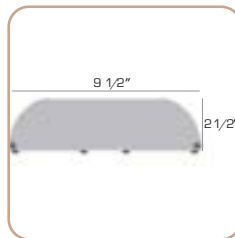
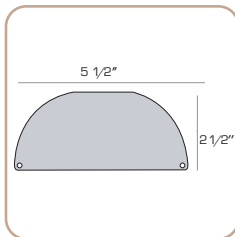
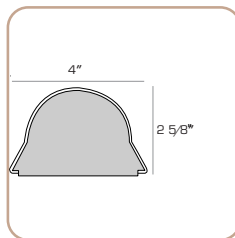

SLIMLINE™ LIGHT

The correct lighting makes the colors of food pop and look the most appetizing. The high-style, high light output, low-profile Stealth Light is the ultimate accessory for showcasing your food. The ultra-thin light is only 1.5" by 1.5" and nearly disappears in your installation. Now customers can focus solely on the food instead of the hardware.

STEALTH WARMER/LIGHT™ COMBO

The new, barely-there Stealth Warmer Light Combo provides the best specs in the industry, yet it is only 70% of the size of traditional box units. At only 2.5"x 5.5", the Stealth Warmer Light Combo nearly disappears once installed. With the lowest touch temperature, highest heat output and longest seamless lengths, coupled with a high CRI fluorescent lamp, it is the ultimate in performance and design.

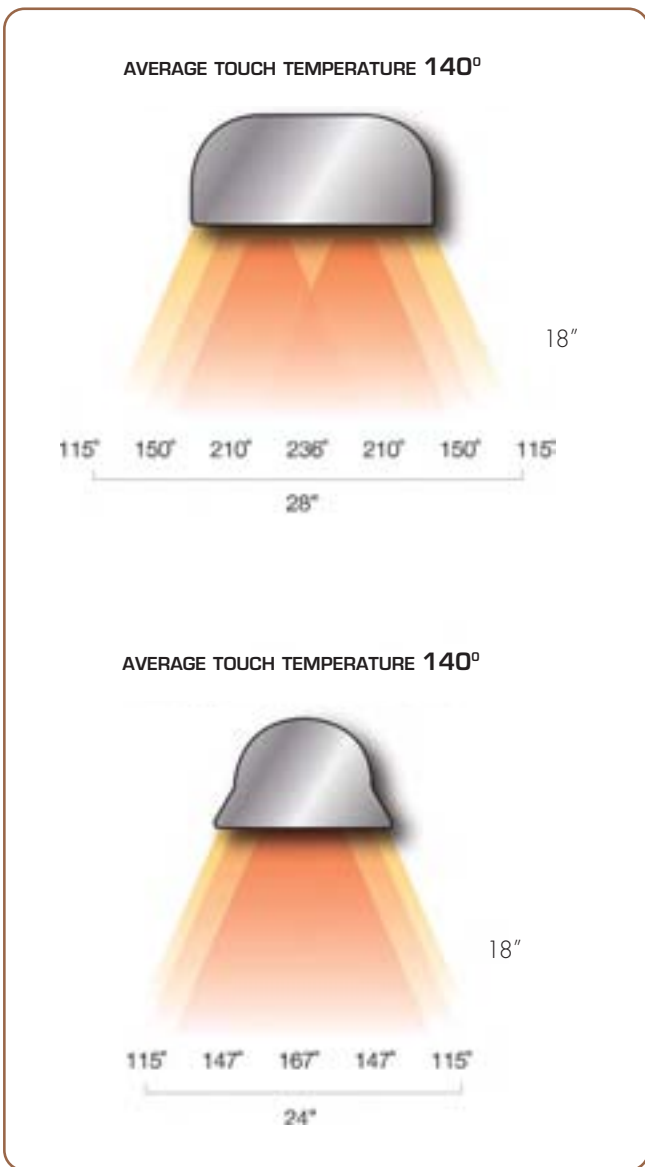



Veggies

Egg Warts

Headliners



INTRODUCING : ZSPACE

DON'T JUST SERVE YOUR FOOD. MERCHANDISE IT

ZSpace is the revolutionary modular food merchandising and point-of-purchase system that lets you take advantage of every inch of your counter space. Now, what used to be empty space above your counters can become a true merchandising opportunity.

Just install the incredible EZ-Clamp anywhere on your ZGuard food shield and add up to three Flexi-Rings. The rings can hold bowls, trivets, vases or any other container to create innovative merchandising displays. From effective P.O.P displays to efficient food delivery systems, ZSpace lets your ideas soar.





EZ-CLAMP/RINGS KITS™

EZ-Clamp lets you start using cubic space to merchandise in ways you never thought possible. The unique swing opening means you can easily install EZ-Clamp on your ZGuard posts without removing any existing hardware. Plus, it installs without any tools.

ZS-100K-5

EZ-Clamp kit comes with 1 each: 4", 5", 8" rings and 1 each EZClamp

DISPLAY TRAY

Clean up your counters with these attractive and functional aluminum shelves. Use them for napkins, oil and vinegar or for P.O.P displays. They are available in either single or double-sided.

ZS-AT1 1-2-EZ (DOUBLE-SIDED)

Includes 2 ea. Aluminum Tray and 1 ea. EZ-Clamp



ZS AT1 1-1-EZ (SINGLE-SIDED)

Includes 1 ea. Aluminum Tray and 1 ea. EZ-Clamp



GLASS TRIVET

These modern and elegant post-mounted trivets add a unique touch to any ZGuard installation. Whether you choose glass or aluminum, the 6" trivet is perfect for a sample tray, pepper mills or condiments or even a bud vase. Available in custom sizes and shapes.

ZS-GS08-EZ

Glass Trivet comes with 1 ea. EZ-Clamp and 1 ea. Glass Trivet comes 8" standard.

ALUMINUM TRIVET

These modern post-mounted aluminum trivets add a unique touch to any ZGuard installation. Durable and beautiful, the 8" disc is perfect for samples, pepper mills, condiments or even a bud vase.

ZS-AS08-EZ

Aluminum Trivet comes with 1 ea. EZ-Clamp and 1 ea. 8" Aluminum Trivet .





WIRE FRAME TRAY

If you have a post, then you have room to create a dramatic design statement with these wire frame trays. You can mount them on top of a post, or cantilever them off the side of any 1" post. The generous 11" tray holds products, samples or decorative accessories.

ZS-WFT-TM Top Mount

Top post-mounted model comes with 1 ea. Wire Frame Tray, 1 ea. Acrylic disc in Milk White, Red, Blue or Purple and 1 ea. post-mount adapter.

ZS-WFT-CM Cantilever Mount

Cantilever-mounted model comes with 1 ea. Wire Frame Tray, 1 ea. Acrylic disc in Milk White, Red, Blue or Purple and 1 ea. "T" fitting.



POST-MOUNTED SIGN

Make any ZGuard installation a Point-of-Purchase display with the Post-Mounted Sign holder. It holds a standard 8.5"x11" sheet of paper to highlight "Daily Specials", directionals, or for any last minute messages. The sign is mounted to a sleeve that just slides over an existing post. For a permanent installation, a separate post and mounting flange kit is available.

ZS-AS011

Post-Mounted Sign comes with top post Mounting Sleeve and folded acrylic sign holder.

CRESCENT SIGN

This minimalist sign is the perfect display solution for modern environments. Attach this unique sign to any post for an upscale look.

The sign can be double or single-sided. The height is fully adjustable and changing graphics is a snap. Available in two convenient sizes, you can easily update graphics on the 8" Crescent Sign from any standard printer.



ZS-CS-11 INCLUDES:

2 ea. 11.5" round acrylic panels, 1 ea. adjustable cantilever sign holder

ZS-CS-8 INCLUDES:

2 ea. 8" round acrylic panels, 1 ea. adjustable cantilever sign holder

POST AND RAIL™ SIGN SYSTEM

Your ZSpace Menu Sign System Starts with the Post and Rail Kit™. This unit can be added to your ZGuard posts or used as a freestanding unit. It mounts to any counter or cart and holds a variety of menu boards and signage systems. Once you determine the length (up to 8'), pick from our menu frames below.

The ZS-PAR Kit includes:

- 2 ea. ZGuard adjustable brackets
- 2 ea. 2" Rails (specify length up to 8')
- 2 ea. 41" ZGuard post (custom lengths available)
- 2 ea. Heavy duty above counter-mounting flange with cover

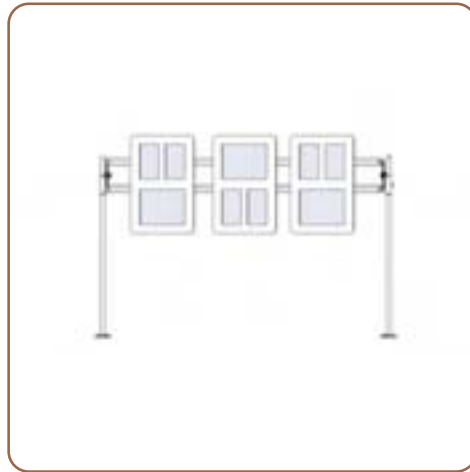

MENU FRAMES

If you want the ultimate in menu and sign flexibility, the Modular Menu Frame system is a perfect solution. Designed to hold standard 8.5 x 11 paper, you can print your graphics, messages or menu items on any printer and change items as often as you wish.



IN ANY SERVERY, SPACE IS AT A PREMIUM.

But with ZSpace™, the revolutionary modular food merchandising system you can take advantage of every inch of your counters and the space above them.

Your food shield isn't only about protecting food anymore — with ZSpace your food shield becomes a sales center. Place ZSpace accessories on every food shield post, and watch the impact your serving line has on your bottom line.

Install the EZ-Clamp on any ZGuard® or Deco-Tech® food shield and add up to three Flexi-Rings or any of our specially designed trivets, shelves or trays and let the merchandising begin.

The EZ-Clamp has a swing opening and quickly installs on any 1" post without any tools. The EZ-Clamp can hold up to 25 pounds securely.

Add up to three Flexi-Rings and use them to hold bowls, plates, vases or any other vessels you want to create stunning point-of-purchase displays, functional condiments stations or simply to add a little spice to your decor.

There simply isn't a more functional or clever way to showcase food. And because it's modular, use it one way for lunch and another way for dinner. From effective P.O.P displays to efficient food delivery systems, ZSpace lets your ideas soar.



LARGE ASIAN DISPLAY



SMALL CONDIMENT DISPLAY



LARGE SNACK DISPLAY



SMALL ASIAN DISPLAY



LARGE BEVERAGE DISPLAY



LARGE SALAD BAR STATION



MEDIUM BEVERAGE DISPLAY



PIZZA STATION



SMALL SALAD BAR STATION



SMALL RING DISPLAY



SMALL BEVERAGE DISPLAY



THREE TEIR DISPLAY

CATERESSEN

PIZZA & ARTISSERIE





INTRODUCING COUTOURA:

It's the only counter system that gives you all the décor and layout flexibility of custom counters, but with shorter lead times, practically no drawing reviews, precise fit and finish, and easy on-site installation.

Whether you're creating curving counters, elegant islands, or simple runs, Contoura makes them all equally simple to design, build and install.

This pre-engineered standard framework removes the need for time-consuming shop drawings and eliminates the majority of on-site surprises, while still delivering better fit and finish.

You get all this and the ability to design a counter that looks totally custom. Simply put: Anything custom can do, Contoura can do — only better.

MORE TIME TO DESIGN

Contoura puts the design back in "designer". By liberating you from the mundane details of counter construction, Contoura lets you focus on the aesthetics and function — not construction techniques. Configure, reconfigure and experiment with bold choices instead of boring details.

SLASH TURNAROUND TIME

Forget reinventing the wheel every day. Design, submit, and install counters in a fraction of the standard time. And by integrating chaseways and eliminating the need for utility walls, Contoura streamlines the installation process by reducing the need for critical field dimensions and simplifying on-site utility connections.

UPDATE WITHOUT DOWNTIME

Contoura's frame and finish are separate. So when you eventually update existing counters we replace only the "skin", leaving the frame in place. This means minimal to no downtime, and much lower labor and material cost.

- Contoura technology eliminates the need for costly and time-consuming welding.
- Aerospace level Solids Modeling CAD systems coupled with laser-cut parts, provide tolerances not available with custom fabrication.
- Reduced project management and installation costs.
- Chaseways are integrated to save time and minimize on-site utility connections.
- Create any shape counter you want, including curves, simple straight runs, and even elegant serpentine layouts. With Contoura, curves come as easy as right angles and are as cost-effective.

COUNTOURA COUNTER SYSTEM



ACCEPT NO COMPROMISES.

Whatever you can do with custom fabrication, you can with Contoura — only better. Contoura is a new way to think about counter design, fabrication and installation. You still get all the design options you're used to, but without all the headaches.

STRONG IS AN UNDERSTATEMENT.

Contoura's technology-driven platform ensures that it's the strongest system available today. Structural supports are made of 3/8 inch steel plate and spaced optimally throughout the counter. Supports for tray slides or extended counter tops can be designed in to into actual frame of the counter, not attached as an afterthought.

Both the feet and food shields are attached via two points and are incorporated into the frame of the counters. Simply put, feet won't fall off and food shields mounts will be stronger than you ever imagined.



THE SHAPE OF THINGS TO COME

- Create any shape counter you want, including curves, simple straight runs, and even elegant serpentine layouts. With Contoura, curves come as easy as right angles and are as cost-effective.
- You specify exact height, width, depth or radius. You are not confined to preset sizes or dimensions.
- Integrate corner transition units to tie seamlessly into the look of the counter with multiple storage options.
- Add storage shelves, plate shelves, doors and drawers.

THE BIG FINISH

- Choose finishes and materials just like you would with custom counters except with Contoura, you'll get a more precise fit, cleaner edges and straighter lines.
- Choose counter tops of granite, solid surface, laminate, stainless steel and more.
- Easily update your look tomorrow or next year. Since the décor is separate from the structure, renovate, redecorate or even repair damaged counters with ease and with little or no downtime.

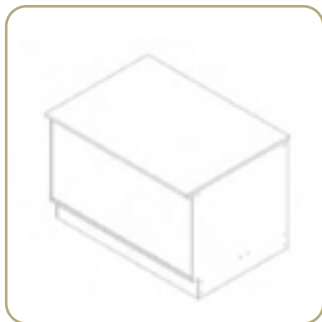
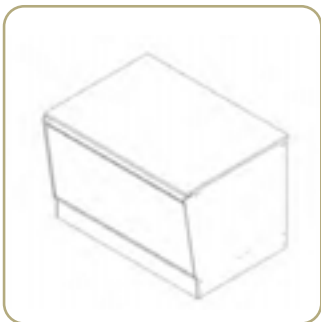





MORE COUNTER, MORE STYLE

Introducing an unprecedented level of elegance, simplicity and agility to servery design with Euro+Serve modular counters.

The custom modular component system is a sophisticated design approach comprised of individual base units and transition pieces, that you use to create counters that rival expensive custom millwork counters.

Designing with Euro+Serve is easy. Determine your layout, maximize the functionality of each unit by adding under-counter storage units, register stands and shelves. Finally, choose your colors and finishes.

Don't worry about being too trendy, because the removal insert panels can quickly be changed to accommodate design or concept changes. You can get a whole new look without the expense and hassle of a remodel.

Choose the elements that go under the counters. No wasted shelves or unused doors. You pick the elements and storage solutions that go under each unit. This approach leaves more of the budget to upgrade the elements that really matter. In addition, Euro+Serve counters are designed to let you to change your servery layout and design to meet the ever-changing needs of today's food service operators.

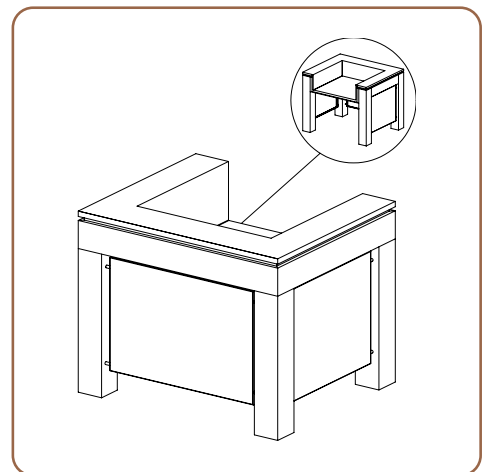

DISPLAY FOOD WITHOUT BARRIERS

Open refrigerated displays move more product—some operators report doubling or tripling sales immediately after installing them. Don't let anything get in the way of your profit.

Open-sided refrigerated merchandisers are commonly called Air Screens. Without a doubt they have been proven as the most profitable way to merchandise cold products.

Regardless of your needs, we have the most complete line of refrigerated Air Screen merchandisers available. Choose from multiple styles including drop-in counter, free-standing, closed-back or pass-through models. We also have any size you need, from 3.5 cu. ft. to 22 cu. ft.



ICE PANS BUILT TO LAST

Fully self-contained, create a food service station anywhere. No need for utilities, just fill it with ice and pre-packaged products.

The attractive streamlined design, plus the variety of available laminates/powder coated colors give you a wide range of choices to complement any decor.

Made of 14-gauge brushed 304 stainless interior and 20-gauge brushed 304 exterior, these are made to last and meet NSF requirements. In addition, they host pressure foamed insulation to keep the cold where it belongs.



Available in a variety of standard sizes, there's one that will fit your needs. Or if you have a specific application we can create custom units.

We also have them as mobile units on legs and casters for the ultimate in merchandising and portability.





HOTTEST WAY TO MERCHANDISE FOOD

Our Solera glass ceramic heated merchandisers combine the best of European styling with innovative technology. With painstaking attention to performance, Solera merchandisers are all built with thermal properties that facilitate superior presentation and holding of hot foods. Our design offers the most consistent heat, and since it uses less wattage per square foot, it is the most efficient.

Choose from either our drop-in models or our counter top "portable" unit. This is the ideal heated merchandiser solution for use on high-end, expensive counter tops. The extraordinary directional thermal properties of the glass transmit heat up through the top, and not on the sides or bottom. The glass remains at a constant temperature (up to 250°); however, the stainless steel sides stay cool to the touch, ensuring your counter tops are safe from heat damage as well as allowing hot foods to be placed next to cold foods.

Our portable units are the cornerstone of the newest trend in "on counter top" design. Display hot foods in decorative containers such as cast iron, porcelain, aluminum and even fine china to enhance the upscale "home made" feel.

New

Our exclusive HTZ portable heated merchandiser includes the revolutionary ZGuard® food shield and the Stealth® Overhead Heat and Light.

Using a standard 120v outlet this unit goes anywhere. Plug it in and you have a safe, effective and beautiful serving station.

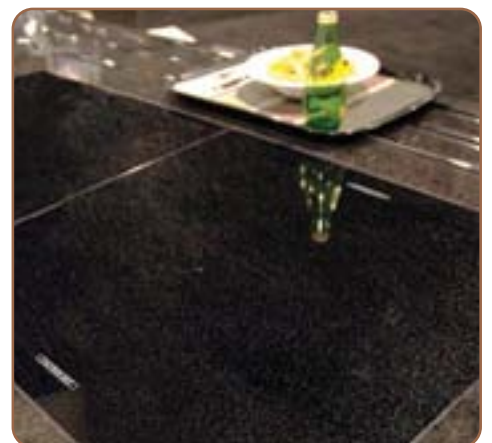

NEW HOT DOTS

This takes out-of-the-box thinking to a whole new level. Introducing our newest innovation: Hot Dots. Take your merchandising in a new direction when you use these round ceramic glass merchandisers. They are a perfect way to make your counter tops run circles around the competition.

Beautifully styled, Hot Dots are flangeless which provides a nearly invisible transition on dark counter tops. Or create a dramatic statement when you use them on lighter counter tops.

Which ever you choose you can be confident that when you install them on your expensive stone tops they won't damage the surface. They offer the same thermal dynamic properties of our other models. The heat goes up, not down or out the sides. They are not only beautiful, they are energy-efficient and the infinite controller gives you complete control over the surface temperature.





SOMETHING IS UNDERFOOT

Most people know us for innovative high-quality products that work. Our comprehensive line of floor troughs are no exception.

We offer a full line of floor troughs that are suited to meet any need. In addition to dozens of standard sizes we can quickly deliver custom orders. We understand that as the construction times shrink the lead time for floor troughs becomes an important issue - we can custom build any drain to fit any need with a standard two week lead-time. An offset hole now no longer a problem. An awkward shape is not a problem.

In addition to offering true positive pitch all our floor troughs comply with NSF Standard 2 Construction, are made of 14-gauge brushed finish type 304 stainless and offer coved corner pans.

CHECK OUT OUR COMPLETE LINE OF:

- Walk-In/Ice Machine Floor Troughs
- Anti-Splash Floor Troughs
- Security with locking Grate Floor Troughs
- Shallow Floor Troughs
- Floor Troughs with Integral Drain Pan

INNOVATIVE SINKS FOR EVERY SITUATION

Sink options include standing units or drawer style; single or multiple faucets; single or multiple basins; integrated hot water heaters; sinks with soap and towel dispensers, trash cans or combinations what ever your need be; units with one, two or no handles. We offer units with electronic motion detectors to dispense water for handwashing. This will eliminate the possible transfer of dirt and germs.





BRASS SMITH INNOVATIONS

3880 Holly Street
Denver, CO 80220

1.800. 662.9595

www.brasssmith.com

www.kevry.com